



FIM40

NITGEN® FIM40 Series

Stand-Alone Fingerprint Recognition Device with Built-in CPU

Datasheet

(Supported Firmware Version: 1.21 or higher)

Version 1.04

© Copyright 2012 NITGEN Co., Ltd.

ALL RIGHTS RESERVED

Serial Number:

Specifications can be changed without notice.

FIM40

Revision Information

Date	Version	Description
2011/01	1.00	release
2011/04	1.01	Describe maximum capacity on FIM30 emulation mode
2011/05	1.02	Add SI_USING_LATENT in Board configuration option
2011/06	1.03	The Feature of Board is modified
2012/02	1.04	Document Renewal DRAM specification is modified

Contents

1. GENERAL DESCRIPTION	6
2. FEATURE	7
3. TARGET APPLICATION.....	7
4. SPECIFICATION	8
4.1. BASIC FEATURE	8
4.2. SENSOR FEATURE.....	9
4.3. INTERFACE FEATURE.....	10
5. BLOCK DIAGRAM	11
6. OPERATION.....	12
RESET.....	12
COMMUNICATION	12
CUSTOM DATA AREA.....	12
IO FUNCTION	12
BOARD CONFIGURATION OPTION.....	12
7. TECHNICAL DATA.....	13
7.1. PHYSICAL CHARACTERISTICS	13
<i>The Feature of Board.....</i>	<i>13</i>
<i>The feature of fingerprint sensor – OPP06.....</i>	<i>14</i>
<i>The feature of sensor Cable.....</i>	<i>15</i>
7.2. EXTERNAL PORT	16
7.3. CONNECTOR	19
7.4. ELECTRICAL CHARACTERISTICS	20
8. ORDERING INFORMATION.....	21
8.1. FIM4060 ORDERING GUIDE.....	21

FIM40

- 8.2. NAMING RULE 22
- APPENDIX A. RECOMMENDATION CIRCUIT AND TIMING.....23**
- RECOMMENDED CIRCUIT TO USE PROGRAMMABLE GPIOs 23
- Circuit for low-active input..... 23*
- Circuit for high-active input..... 24*
- Circuit for normal and inverted output 25*
- SENSOR CAPTURING TIMING IN PROGRAMMABLE GPIOs 26
- BOOT UP TIME 27
- APPENDIX B. SUPPORT INFORMATION28**

1. General Description

Biometric systems are recently used in various authentication systems. They are increasingly used not only in environments that require high level of security but also in many other places because they are convenient and economical. Among various biometric systems, the fingerprint recognition system takes up most of the market because it is easy to use as well as economical and capable of developing various types of applications. NITGEN, a global leader in the fingerprint recognition industry, provides various fingerprint authentication solutions such as PC security, knowledge management, vaulting service, access control, electronic approval, and financial payment. NITGEN actively responds to customer needs through continuous research, development and quality management.

FIM40 is a stand-alone Fingerprint Identification Device with many excellent features. It provides benefits such as high identification performance, low power consumption and two UART serial interfaces with the various commands for easy integration into a wide range of applications. It is a durable and compact device with fingerprint identification module containing NITGEN® optics-based fingerprint sensor inside.

2. Feature

- ◆ One ID multi-templates mode
- ◆ Emulation Mode for compatibility with FIM20 and FIM30 series
- ◆ Up to 20,000 Templates
- ◆ More than 50,000 Logs
- ◆ Using New optical sensor OPP06
- ◆ Changeable user's verification security level
- ◆ Selectable UART communication Level (RS232 or LVCMOS)
- ◆ Selectable fingerprint rotation angle range (+/- 45 ° or +/- 180 °)
- ◆ Support Auto-Identify mode
- ◆ Support ISO19794-2 and ANSI 378 template format
- ◆ Support Device Master password
- ◆ Provide custom data area
- ◆ Compatible template format with NITGEN eNBio API
- ◆ 8 Programmable GPIOs

3. Target Application

- ◆ Access Controller
- ◆ Time and attendance management solution
- ◆ Security solution
- ◆ Safety Box
- ◆ ATM, POS and more

4. Specification

4.1. Basic Feature

Hardware Specification

ITEM		FIM40
Board Spec.	CPU	S3C2450 (ARM9 533Mhz)
	DRAM	64MByte
	Flash ROM	16MByte
Dimension		40 x 45 [mm ²]
Sensor		NITGEN OPP06
Supply Voltage		5 / 3.3 [V]
Current Consumption	Normal	120 [mA]
	Max	130 [mA]
Operating Temperature		-20 ~ 60 [°C]
Humidity		~ 90 [% RH]
ESD Tolerance		±8 [KV] (indirect)
Communication Channel		2 UART (RS-232 Level, LVCMOS Level) Speed: 9600 ~ 115200 [bps] (1 start bit, 8 data bit, no parity, 1 stop bit)
External I/O		8 Programmable GPIOs
Maximum Template Storage		Up to 20,000 templates ¹⁾
Maximum Log Storage		Up to 55,269 Logs

¹⁾ (Up to 10,000 users can be stored in FIM20 2 templates emulation mode & Up to 5,000 users can be stored in FIM20 4 templates emulation mode).

Operation Specification

ITEM	FIM40
Capture Speed	22 [msec]
Verification Speed	Less than 700 [msec]
Boot Up Time ¹⁾	125 [msec] for 100 templates 280 [msec] for 1,000 templates 880 [msec] for 5,000 templates 1,730 [msec] for 10,000 templates 3,450 [msec] for 20,000 templates
Data Encryption Method	AES for saving data AES for DB communication

¹⁾ Boot-up time is explained in Appendix A.

4.2. Sensor Feature

OPP06

Sensor Name	OPP-06
Sensing Type	Optical
Sensing Area	15.0mm x 18.5mm
Image Resolution	500 DPI
Image Size	260 x 300

4.3. Interface Feature

Interface	
Communication Channel 0 (LVCMOS Level)	LVCMOS Up to 115200bps Baud Rates supported (Default : 9600bps)
Communication Channel 1 (RS232 Level)	RS-232C Up to 115200bps Baud Rates supported (Default : 9600bps)
I/O	8 Programmable GPIOs

5. Block Diagram

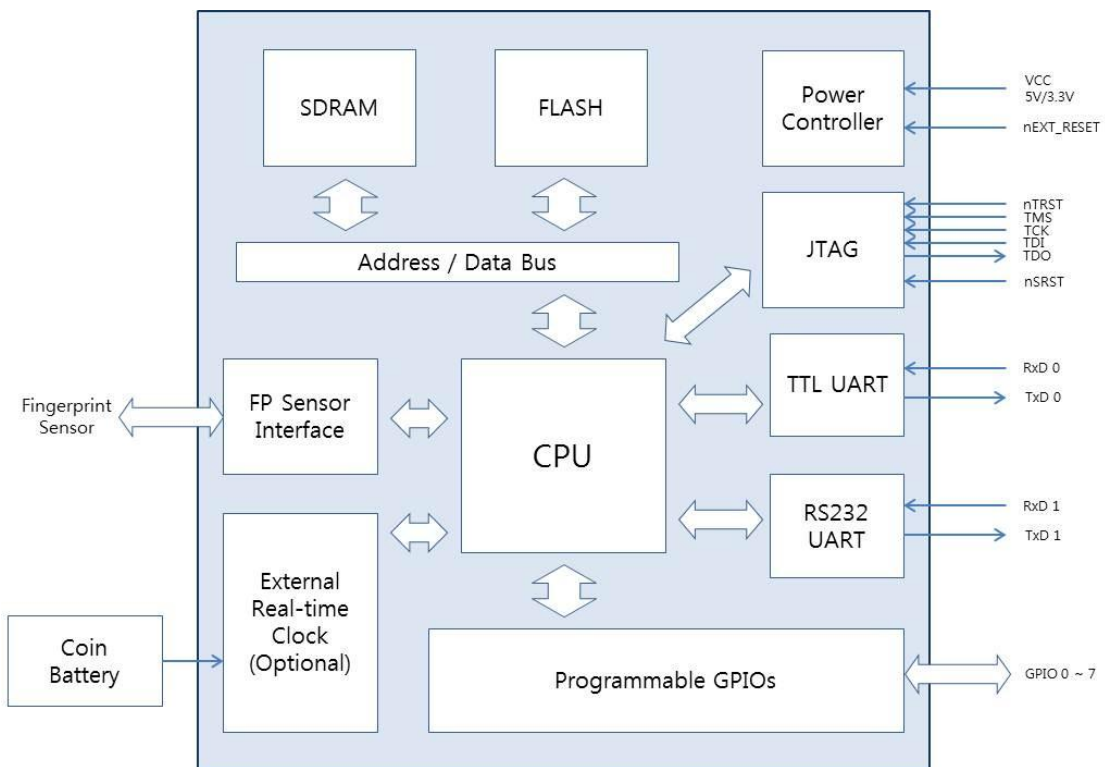

RS-232C communication data consist of 8-bit data, no parity, 1-bit start-bit and 1-bit stop-bit.

6. Operation

Reset

FIM40 provides external low-active reset signal port. By setting the reset port low state, FIM40 could be initialized. The reset port is internally pull-uped to VCC.

Communication

FIM40 has two UART serial communication ports (RS232C and LVCMOS level) through those FIM40 communicates at the same time. These ports support 6 baudrate modes such as 9600, 14400, 19200, 38400, 57600, and 115200 bps.

FIM40 follows NITGEN Serial Communication protocol. For more detail information, please refer to the FIM ComProtocol document.

UART data consists of 1 start bit, 8 data bit, no parity bit and 1 stop bit.

Custom Data Area

FIM40 provides 64 Kbytes flash memory. By using this memory, host can save private data for specific usage. The caution is needed for the responsibility for reading, writing and erasing because user data area is given to the host.

IO Function

FIM40 provides 8 programmable GPIOs. These GPIOs can be configured or activated as normal IO, key function, result output, capturing status and so on.

Please refer clause 7 of FIM ComProtocol Vol2. ErrorCode & Structures document to get more details.

Board configuration option

The following table shows board configuration system option.

These option values can be changed by using NITGEN Serial Communication protocol.

Please refer CMD_SET_SYSINFO (0x4C) and CMD_GET_SYSINFO (0x4D) commands of FIM ComProtocol Vol1. Overview & Commands document to get more details.

FIM40

7. Technical Data

7.1. Physical Characteristics

The Feature of Board

[Unit: mm]

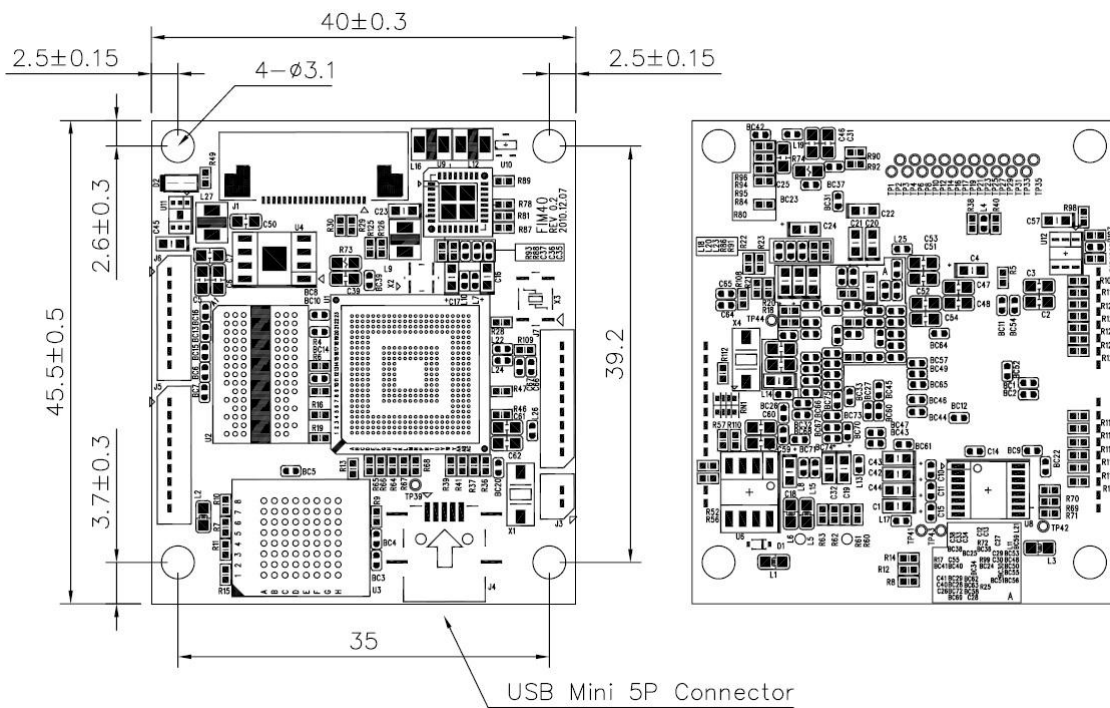

* USB connector (J4) can be mounted for providing USB functionality without notice.

FIM40

The feature of fingerprint sensor – OPP06

[Unit: mm]

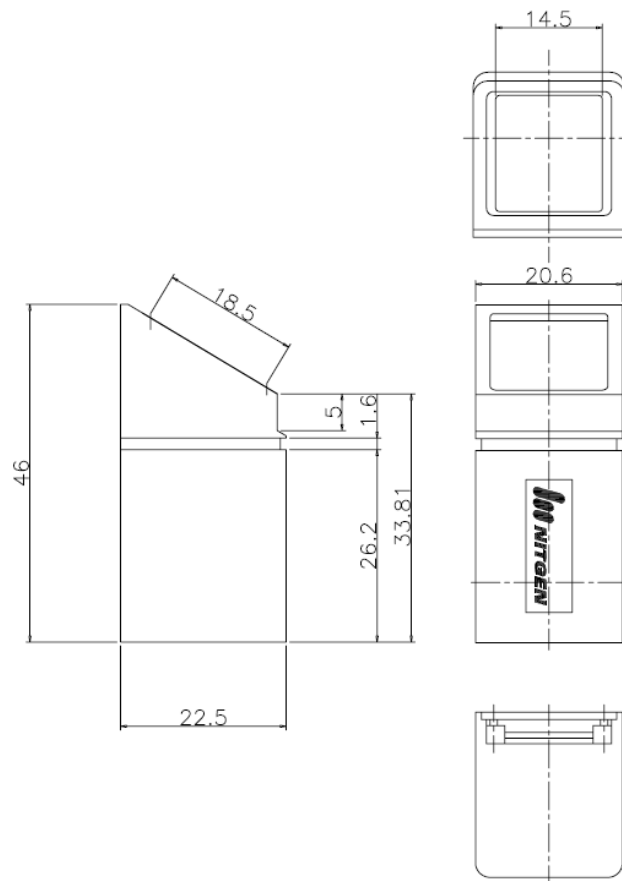

FIM40

The feature of sensor Cable

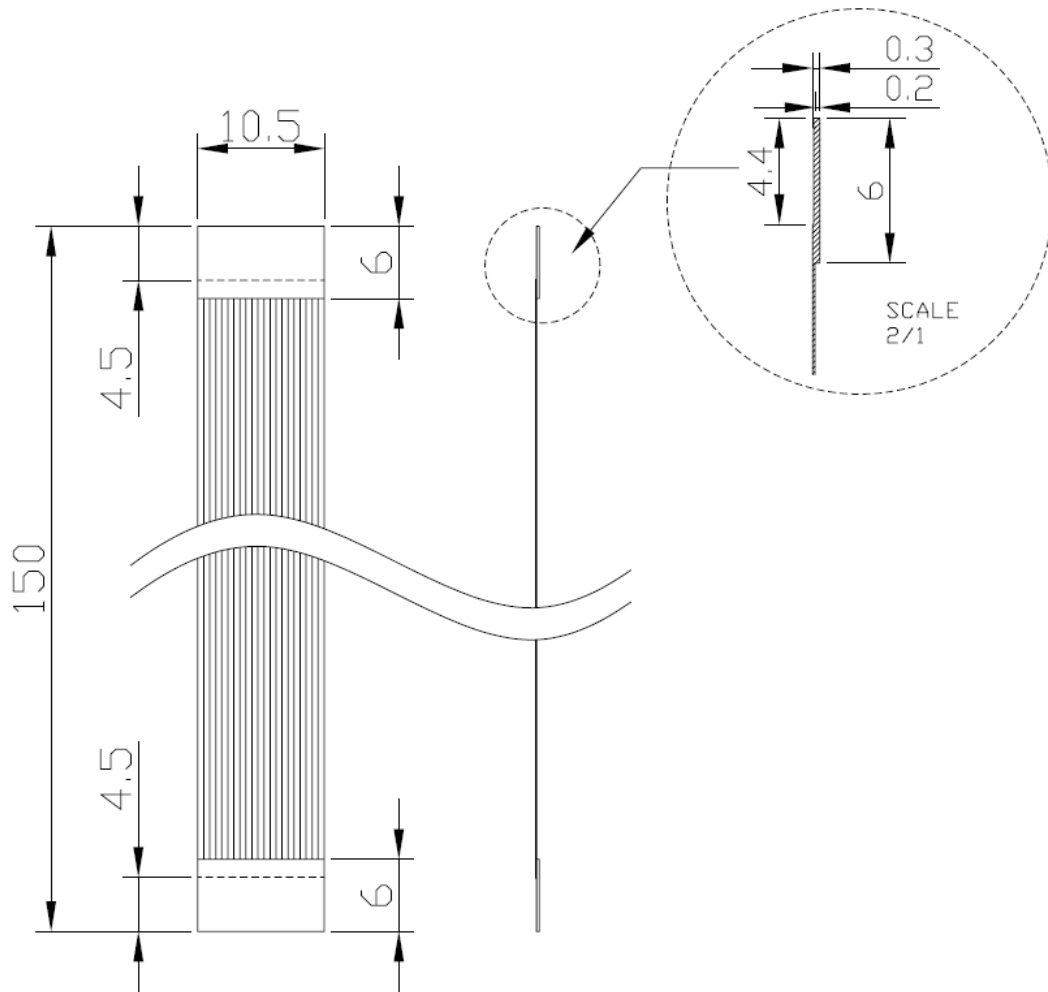

FIM40

7.2. External Port

20-Pin OPP06 Sensor connector (J1)

Pin	Pin Name	Description
1	GND	Sensor Ground
2	VCLK	Sensor System Clock
3	VCC	Sensor VCC (3.3V)
4	AUTO-ON	Sensor Auto-On
5	RST	Sensor Reset
6	VSYNC	Vertical Sync.
7	HSYNC	Horizontal Sync.
8	SDATA0	Sensor Data 0
9	SDATA1	Sensor Data 1
10	SDATA2	Sensor Data 2
11	SDATA3	Sensor Data 3
12	SDATA4	Sensor Data 4
13	SDATA5	Sensor Data 5
14	SDATA6	Sensor Data 6
15	SDATA7	Sensor Data 7
16	SDA	I2C Data
17	SCL	I2C Clock
18	LED 1	Sensor LED 1
19	PIXCLK	Pixel Clock
20	LED 2	Sensor LED 2

External Real-time Clock Connector (J3)

Pin	Pin Name	Description
1	VCC	3.3V
2	GND	Ground

FIM40

USB Connector (J4)

Pin	Pin Name	Description
1	VCC	5V
2	PDN0	Data[-] for USB peripheral
3	PDPO	Data[+] for USB peripheral
4	GND	Ground
5	ESD_GND	Connected with connector's case

9-Pin External Connector (J5)

Pin	Pin Name	Description
1	VCC	Supply Voltage (5V ~ 3.3V)
2	EXT_RXD	UART Channel 1 port receiving signal from host (RS232 Level)
3	EXT_TXD	UART Channel 1 port transmitting signal to host (RS232 Level)
4	TTL_RXD	UART Channel 0 port receiving signal from host (LVCMOS Level)
5	TTL_TXD	UART Channel 0 port transmitting signal to host (LVCMOS Level)
6	GPIO0	General Purpose Input / Output 0
7	GPIO1	General Purpose Input / Output 1
8	/EXT_RESET	Reset signal – active low
9	GND	Ground

8-Pin External Connector (J6)

Pin	Pin Name	Description
1	VCC	3.3V
2	GPIO2	General Purpose Input / Output 2
3	GPIO3	General Purpose Input / Output 3
4	GPIO4	General Purpose Input / Output 4
5	GPIO5	General Purpose Input / Output 5
6	GPIO6	General Purpose Input / Output 6
7	GPIO7	General Purpose Input / Output 7
8	GND	Ground

FIM40

JTAG Connector (J7)

Pin	Pin Name	Description
1	VCC	3.3V
2	N/A	N/A
3	nSRST	JTAG control pin
4	TDO	JTAG control pin
5	TDI	JTAG control pin
6	nTRST	JTAG control pin
7	TCK	JTAG control pin
8	TMS	JTAG control pin
9	GND	Ground

* J7 (JTAG connector) is used only for development or emergency recovery.

FIM40

7.3. Connector

Sensor

NO	DESCRIPTION	VENDOR
1	20-PIN (52746-2090)	MOLEX

Communication

NO	DESCRIPTION	VENDOR
1	9-pin Male (53047-0910)	MOLEX
2	8-pin Male (53047-0810)	MOLEX

FIM40

7.4. Electrical Characteristics

Parameter	MIN.	TPY.	MAX.	UNITS
Power				
Supply current			200	mA
Supply Voltage	3.0	3.3 / 5.0	5.5	V
UART (RS-232 Level)				
Output Voltage Swing	±5.0	±5.4		V
Input Voltage Range	-15		+15	V
Input Threshold LOW	0.6	1.2		V
Input Threshold HIGH		1.5	2.4	V
Maximum data rate			115,200	BPS
UART (LVCMOS Level)				
Output Voltage LOW			0.4	V
Output Voltage HIGH	2.7		3.3	V
Input Threshold LOW			0.8	V
Input Threshold HIGH	2.4		3.3	V
Maximum data rate			115,200	BPS
GPIO				
Output Voltage LOW			0.4	V
Output Voltage HIGH	2.7		3.3	V
Input Threshold LOW			0.8	V
Input Threshold HIGH	2.4		3.3	V
E.T.C.				
Reset pulse Width	1			ms

8. Ordering Information

8.1. FIM4060 Ordering Guide

Product Name	Max. Templates	Supply Voltage [V]	RTC
FIM4060-HV	20,000	3.3 / 5	Internal
FIM4060-HVM2	20,000	3.3 / 5	External

FIM40

8.2. Naming Rule

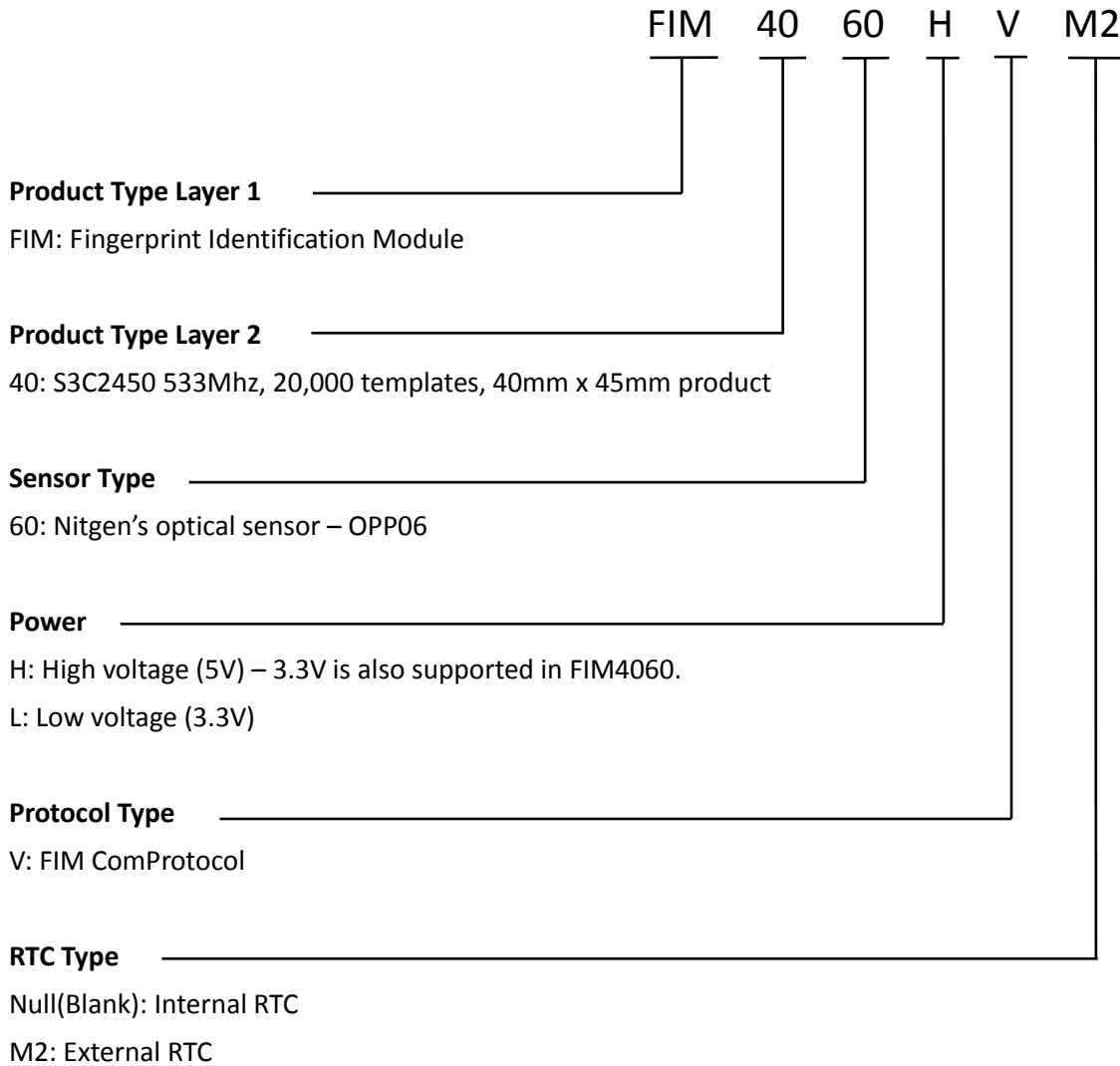

APPENDIX A. Recommendation Circuit and Timing

Recommended circuit to use programmable GPIOs

Circuit for low-active input

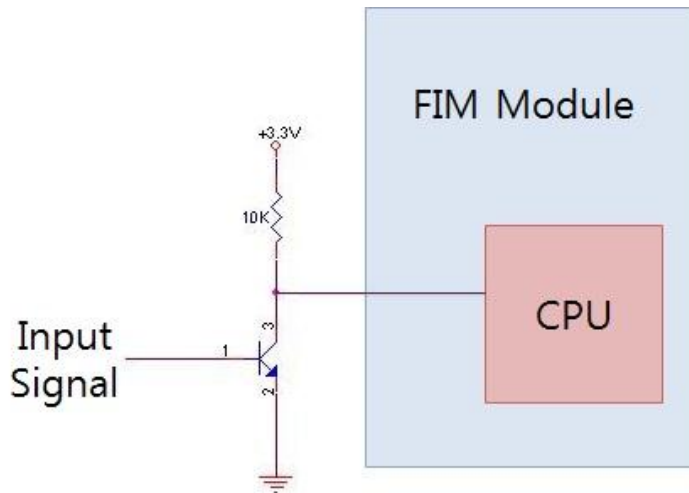

This circuit is recommended for,

- ◆ GPIO_IN_NORMAL (0x00)
- ◆ GPIO_IN_ENROLL_LOW (0x02)
- ◆ GPIO_IN_DELETE_LOW (0x04)
- ◆ GPIO_IN_IDENTIFY_LOW (0x06)

*All GPIO definitions are defined in clause 7 of FIM ComProtocol Vol2. ErrorCode & Structures document.

FIM40

Circuit for high-active input

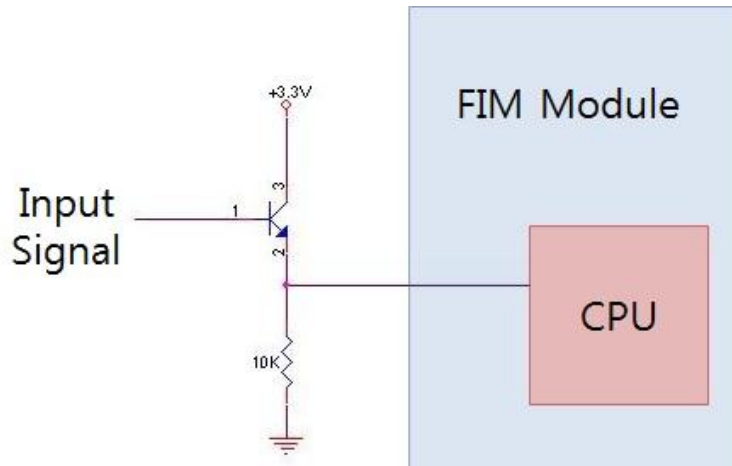

This circuit is recommended for,

- ◆ GPIO_IN_NORMAL (0x00)
- ◆ GPIO_IN_ENROLL_HIGH (0x01)
- ◆ GPIO_IN_DELETE_HIGH (0x03)
- ◆ GPIO_IN_IDENTIFY_HIGH (0x05)

FIM40

Circuit for normal and inverted output

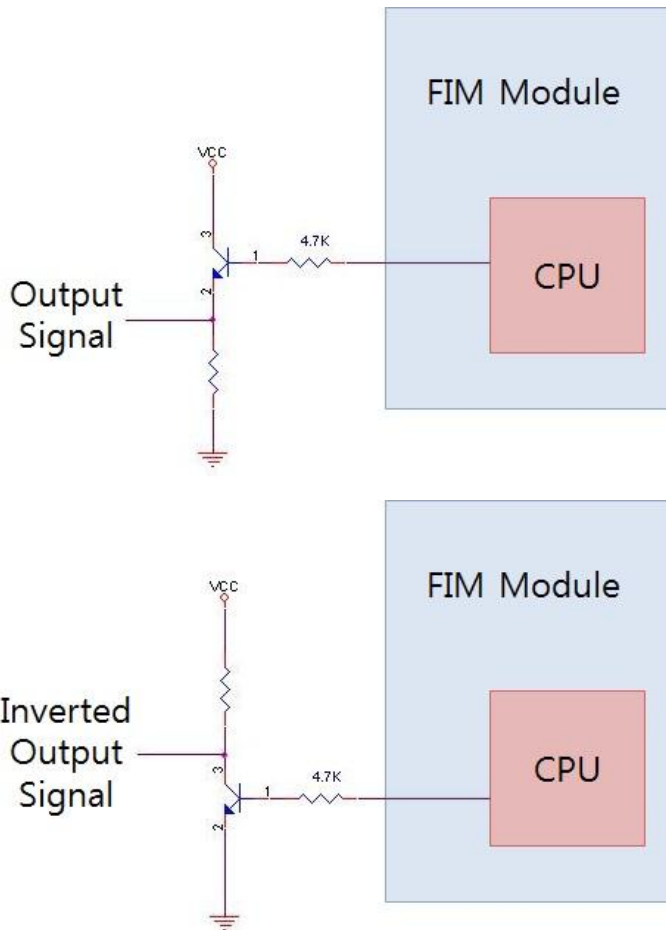

This circuit is recommended for,

- ◆ GPIO_OUT_NORMAL (0x80)
- ◆ GPIO_OUT_SUCCESS_HIGH (0x81)
- ◆ GPIO_OUT_SUCCESS_LOW (0x82)
- ◆ GPIO_OUT_FAIL_HIGH (0x83)
- ◆ GPIO_OUT_FAIL_LOW (0x84)
- ◆ GPIO_OUT_CAPTURING (0x85)
- ◆ GPIO_OUT_FP_STATUS (0x86)

Sensor Capturing timing in programmable GPIOs

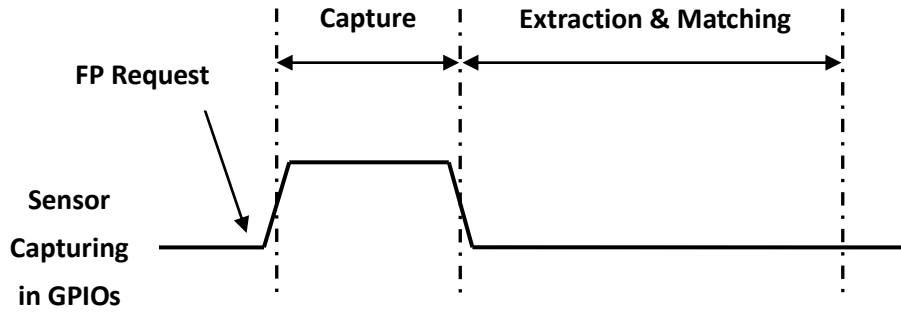

FIM40

Boot up time

System Boot-up time means the total time consumed by FIM40 after system power and **/Reset** are supplied.

Boot-up time depends on the number of templates stored in FIM40.

System Boot-up time can be measured as the following.

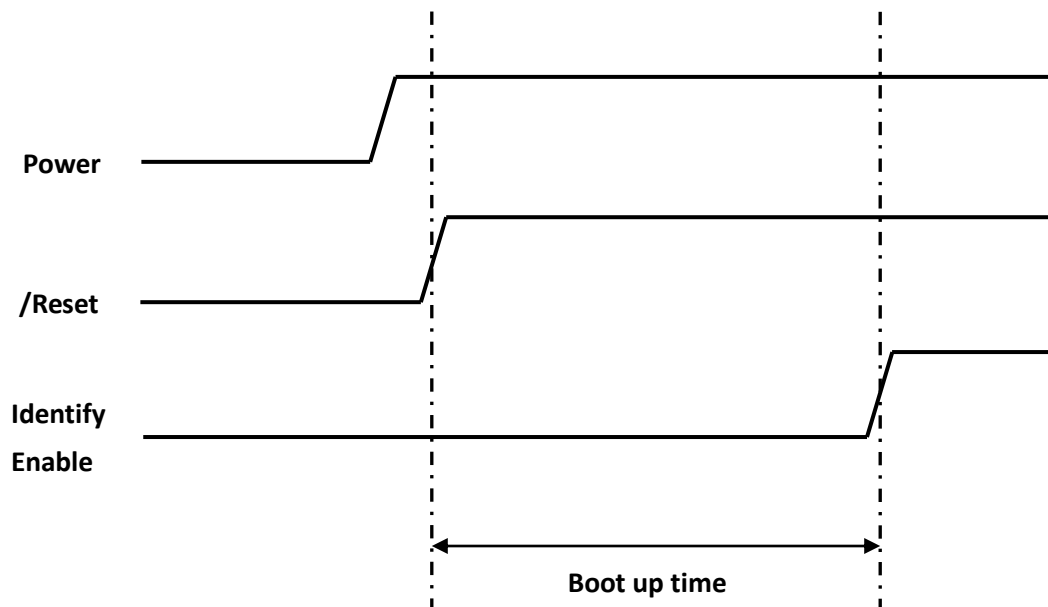

Appendix B. Support Information

A large, light blue circular graphic with a white border, centered on the page. Inside the circle, the company name and contact information are listed.

NITGEN&COMPANY CO., LTD.

B-12F PaxTower Nonhyun-dong, Gangnam-gu,

Seoul, 135-010 Korea

Tel: +82-2-556-7115

Fax: +82-2-556-7118

E-mail: Customer@nitgen.com